

SITE

SPACE IN THE ENVIRONMENT
198 Hackney Road, London E2 7QL
@spaceintheenvironment

A completely self-contained unit over two floors with open air courtyard at the rear. The shopfront is fully glazed with the entrance direct from the street.

Street level:

Approx 45m² / 484sqft (2.8m ceiling height)

- all walls and ceiling are painted white
- natural cork flooring
- dimmable down lights and ceiling uplights
- adjustable hanging system for artwork on all main walls
- wall mounted birch plywood pegboard with adjustable pegs and shelves
- bar height birch plywood counter/shelf
- lockable understair storage cupboard
- multiple power points

Rear Courtyard:

Approx 23m² / 247sqft (3.5m wall height)

- Open air, south facing, high walled

Basement level:

Approx 15m² / 160sqft (1.9m ceiling height)

- gender neutral WC with wash basin
- kitchen/store with s/s sink unit, fridge and worktop

Rates: Prices available on request.

Enquiries: info@spaceintheenvironment.com





SITE

SPACE IN THE ENVIRONMENT
198 Hackney Road, London E2 7QL
@spaceintheenvironment

GENERAL INFORMATION

What's included in the space

Full use of all areas, fixtures and fittings described, plus:

- Wireless broadband
- Heat and power (electricity only)
- Water and sewage
- Fresh air-exchange and extraction

Furniture

See separate sheet for information about furniture and display equipment supplied with the space. Other furniture can be hired on request.

Hours of use

Standard hours of use are between 8am – 8pm from Monday to Sunday.
Hours can be extended on request.

About the area

Situated on busy Hackney Road, close to Hoxton and Shoreditch, and less than 1 minute's walk from Columbia Road. Opposite one of the most popular restaurants in London, Morito, and fashionable wine bar Sager and Wilde. The local residential community includes young professionals and families with a strong community of creative studios and other businesses, occupying the streets during the week. On Sundays, both Londoners and tourists from all over the globe flock to the world-famous Columbia Road Flower Market before visiting the bars, restaurants, galleries and local shops. The closest station is Hoxton, a short walk from the space.

Parking / Drop Off

There is no parking at the property, but it is possible to load/unload directly outside at your own risk (double yellows). There is voucher parking nearby.

Security

There are metal roller shutters with padlocks on the shopfront.

Catering

There are no cooking facilities and no commercial kitchen extraction in the space, however there is a worktop, sink and fridge for simple preparation and food/drink storage in the basement. Please note we will only permit 100% vegan food and drink preparation in the space.

Our sister space is EDIT, a sustainable plant-based restaurant on Mare Street in Hackney. Enquire for supper club catering, or event/party canapés and drinks etc.

Alcohol

There is a premises licence for both on and off sales of alcohol. If you wish to sell alcohol you will need to appoint your own Designated Premises Supervisor.

Music

Background music can be played, but loud or amplified music is not permitted due to the proximity of our neighbours.

Marketing

We can provide graphic design for digital, print and display media on request.

Insurance

The building is insured but use of the furniture and display equipment is at your own risk. You are responsible for your own contents, product, public liability and employers liability insurance.

Payment

Full payment and deposit must be received before commencement of hire.

Deposit

£300 deposit will be required to secure the booking. Once the space has been returned back to a clean state, keys returned and any redecoration/repairs as necessary, the deposit will be returned.

SITE

198 HACKNEY ROAD LONDON E2 7QL

STREET LEVEL FLOOR PLAN - INTERNAL AREA approx 45sqm (484sqft) - EXTERNAL AREA approx 23sqm (247sqft)

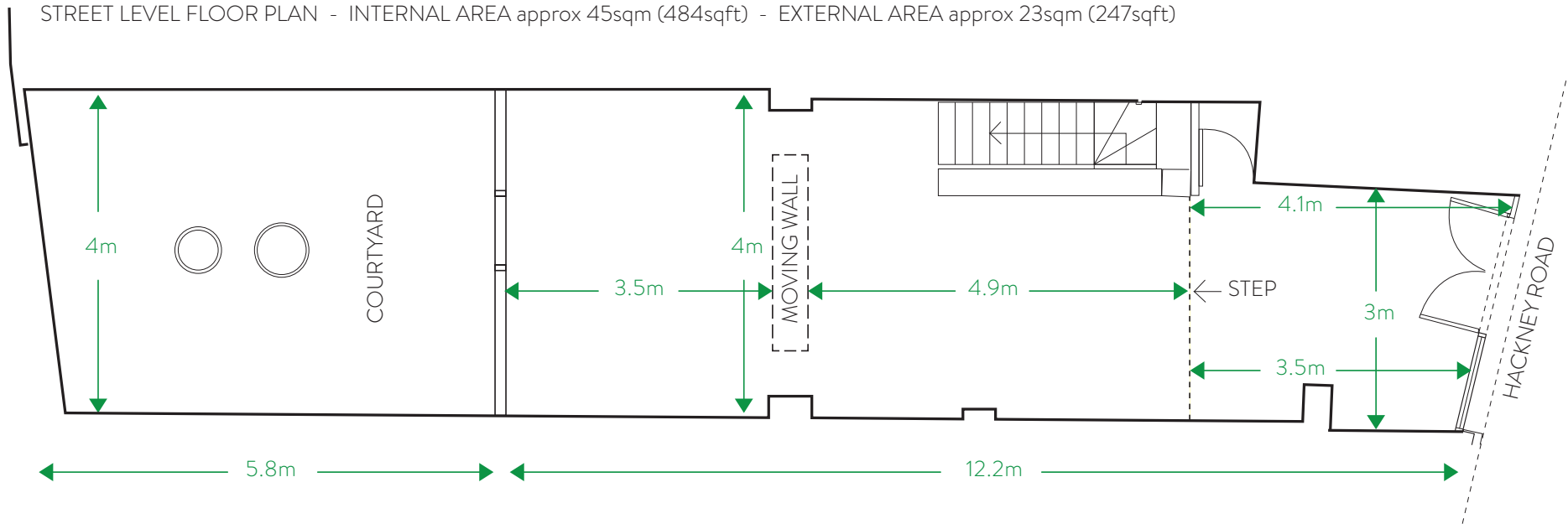

BASEMENT LEVEL FLOOR PLAN approx 15m² (161sqft)

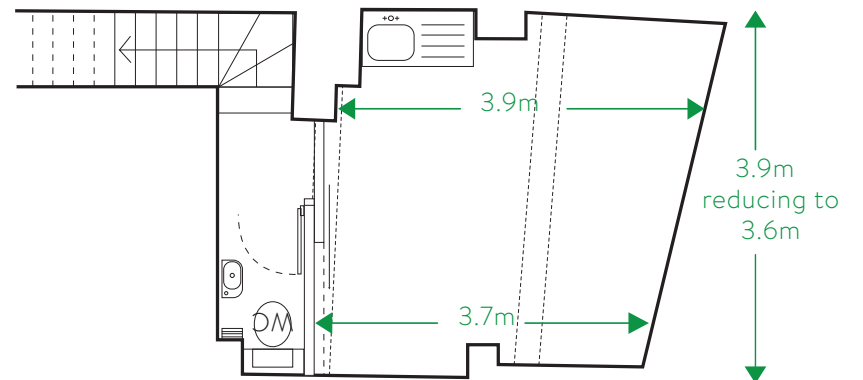

TOTAL INTERNAL AREA approx 60sqm (645sqft)
TOTAL AREA INCLUDING COURTYARD 83sqm (892sqft)

SITE

198 HACKNEY ROAD LONDON E2 7QL

SECTION LOOKING WEST (indicative only)

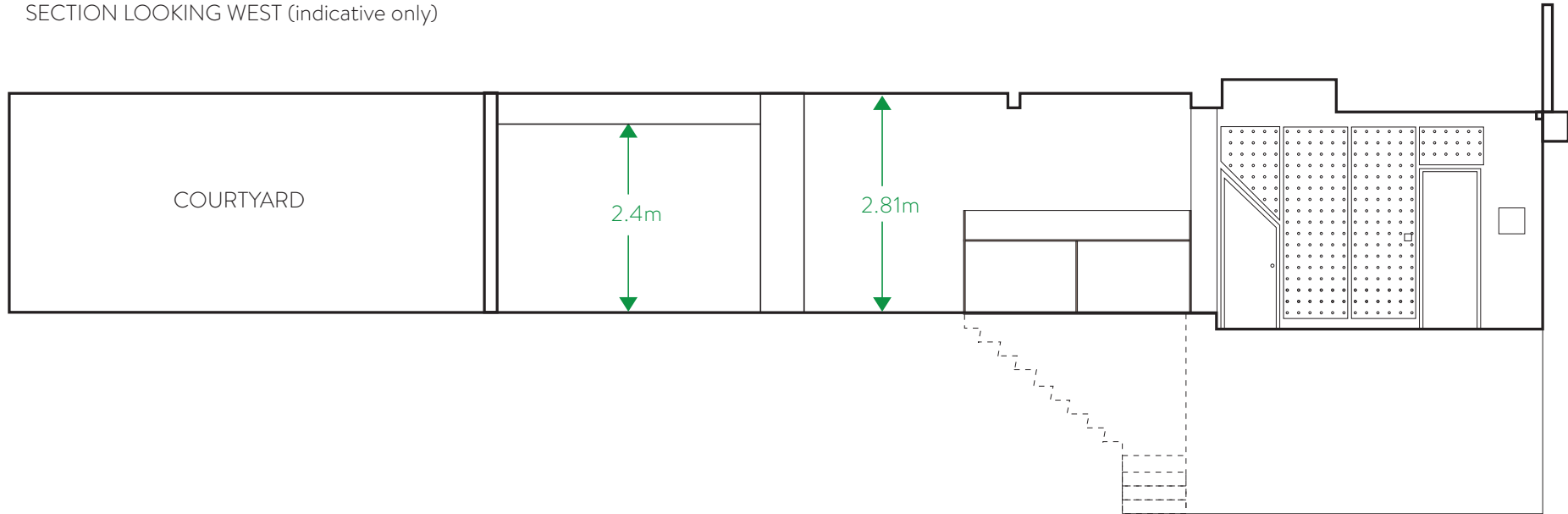

SECTION LOOKING EAST (indicative only)

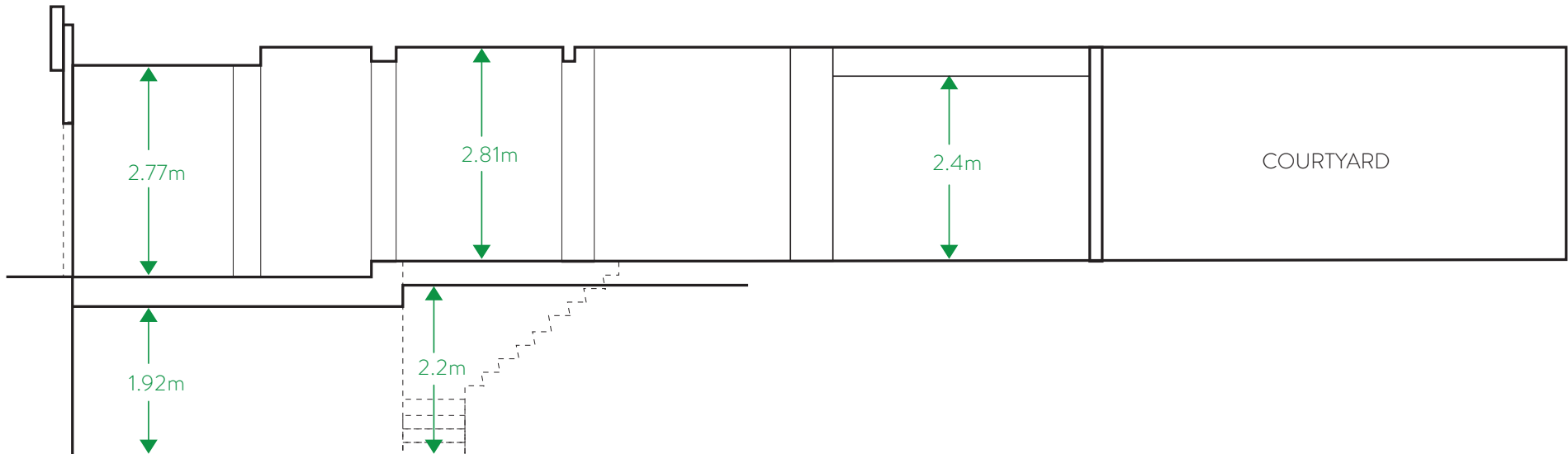

SITE

FURNITURE, DISPLAY FIXTURES AND EQUIPMENT

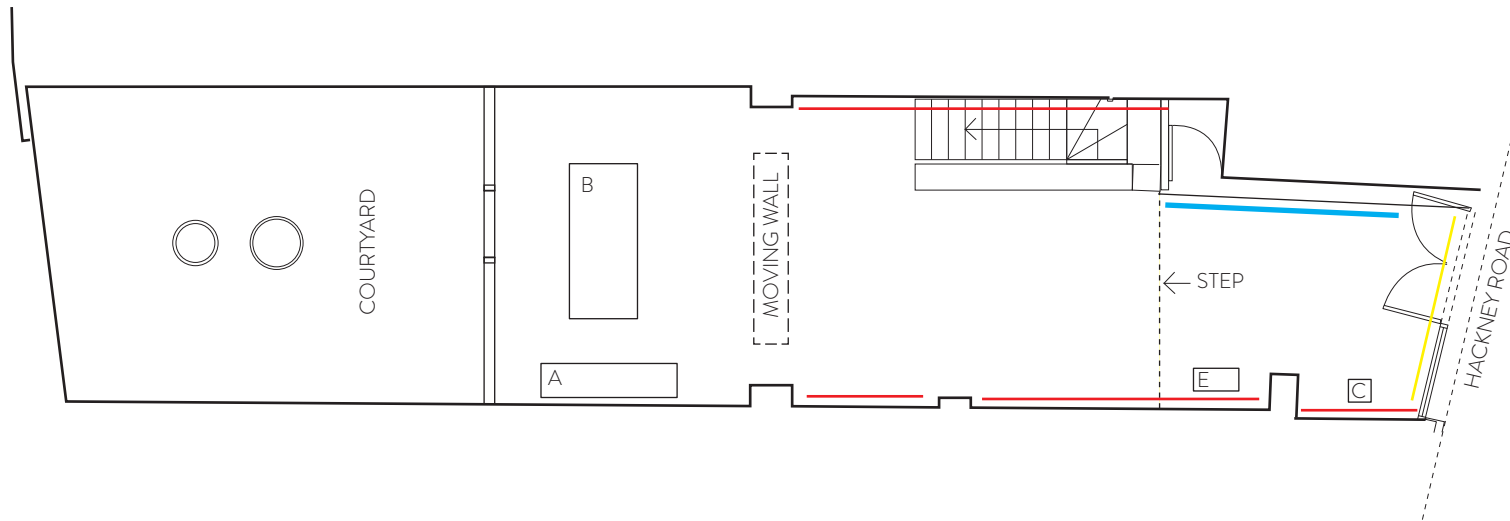

DISPLAY FIXTURES + EQUIPMENT (can not be removed)



Moving wall for artwork or screenings
2575 wide x 2420 tall x 430mm thick



Hanging rails for artworks (STAS Cliprail Max)
Can support artworks of average weight,
up to 25 kg per linear metre
Hanging wires x 34
Adjustable pinch hanging hooks x 45



Birch Plywood Peg Board
Pegs x 30
Shelves x 20 (3 x sizes)



Concealed wooden curtain pole suitable for
hanging heavier items in window

ADDITIONAL DISPLAY FURNITURE (can be removed)



Scaffold shelving with 3 adjustable shelves
300 x 1800mm



Oak table top on trestle legs
900 x 2050mm



Plinth - ply
300 x 300 x 700mm



Plinth - ply
300 x 300 x 700mm



Plinth - ply
300 x 600 x 700mm

CHAIRS

Dark bentwood stackable chairs x 6
Red metal frame high stool x 1

SPACE CONSIDERATIONS



1 person =
600mm minimum

2 persons =
900mm minimum / 1800mm ideal
(750mm minimum for 'pinchpoints')

Max Capacity:

Ground floor (inside) = 30 persons
Courtyard (outside) = 25 persons
(weather dependent)

All supplied free of charge and used at your own risk. Please note that any missing items or damage caused will be deducted from your deposit.